

PCM-3P-PC802 - LTE/5G O-RAN Small Cell Outdoor Radio Reference Design



Samantha Williams

Product Summary

The PCM-3P-PC802 is a 5G NR and LTE small cell outdoor O-RU reference design. This platform is designed for seamless interfacing and evaluation of AFE77xxD with Picocom PC802R for split 7.2 Radio Unit (O-RU) with low PHY functionality. This reference design solves essential design challenges to expedite development. The digital board contains TI's AFE77xxD transceiver with integrated DPD, CFR, and a single PC802 which is connected to a co-processor. (TI's Sitara™ AM64xx processor) design includes baseline software architecture for 7.2× split, PTP stack and servo, PA biasing and protection and VSWR. This can expedite time to market for a customer.

Overall Architecture

The different subsystem boards are designed and provided to achieve high performance, noise isolation, and thermal management. Hardware includes:

- Digital board:
 - Analog front end: [AFE7769D](#) (TI)
 - 5G small cell O-RU SoC: [PC802R](#) (Picocom)
 - Co-processor: [AM6412](#) (TI)
 - Clock synchronizer: [LMK5C33414](#) (TI)
- High Power RF Front End Board:
 - Outdoor 5-W small cell
 - Pre-amplifier: [LMH9135](#) (TI)
 - Pre-driver: [MAAM-011324](#) (Macom)
 - Power amplifier: [A5M36TG140](#) (NXP)
 - Power amplifier monitor and controller: [AFE10004](#) (TI)
- Cavity filter:
 - Cavity filter with a frequency range of 3.4 to 3.6 GHz
- Mechanical enclosure, heat sinks, and appropriate shielding

Key Features

- TI AFE7769D 4T4R integrated transceiver
- Picocom [PC802R](#) 5G small cell O-RU SoC
- Co-processor, TI Sitara AM6412 processor
- Synchronization and clocking on board through IEEE-1588 PTP through [LMK5C33414](#)
- RFFE tuned and designed for N78 TDD Duplex Mode (3.5-GHz center frequency)
- RF board using NXP [A5M36TG140](#)
 - Dual stage module designs integrating LDMOS integrated circuit as driver and GaN as a final stage amplifier.
- SFP+ connector for 25-G data transfer for front haul communication eCPRI
- Three UART serial interfaces which facilitate micro-USB port access, sync control for the GNSS receiver, and debug headers.

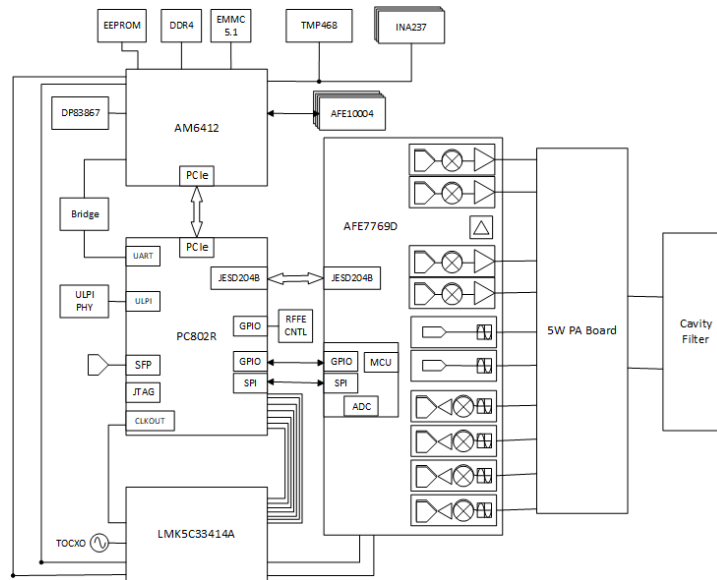

Figure 1. Reference Design Block Diagram

Related Documentation

Documentation	Description	Location
PCM-3P-PC802 quick start guide	Supports immediate bring up and commonly seen challenges within customer bring up.	TI's mySecure portal
PCM-3P-PC802 user's guide	Provides all collateral supporting reference design including use cases, hardware, software, and pinout.	TI's mySecure portal
PCM-3P-PC802 schematic	Schematic files	TI's mySecure portal
PCM-3P-PC802 layout	Layout files	TI's mySecure portal

IMPORTANT NOTICE AND DISCLAIMER

TI PROVIDES TECHNICAL AND RELIABILITY DATA (INCLUDING DATA SHEETS), DESIGN RESOURCES (INCLUDING REFERENCE DESIGNS), APPLICATION OR OTHER DESIGN ADVICE, WEB TOOLS, SAFETY INFORMATION, AND OTHER RESOURCES "AS IS" AND WITH ALL FAULTS, AND DISCLAIMS ALL WARRANTIES, EXPRESS AND IMPLIED, INCLUDING WITHOUT LIMITATION ANY IMPLIED WARRANTIES OF MERCHANTABILITY, FITNESS FOR A PARTICULAR PURPOSE OR NON-INFRINGEMENT OF THIRD PARTY INTELLECTUAL PROPERTY RIGHTS.

These resources are intended for skilled developers designing with TI products. You are solely responsible for (1) selecting the appropriate TI products for your application, (2) designing, validating and testing your application, and (3) ensuring your application meets applicable standards, and any other safety, security, regulatory or other requirements.

These resources are subject to change without notice. TI grants you permission to use these resources only for development of an application that uses the TI products described in the resource. Other reproduction and display of these resources is prohibited. No license is granted to any other TI intellectual property right or to any third party intellectual property right. TI disclaims responsibility for, and you will fully indemnify TI and its representatives against, any claims, damages, costs, losses, and liabilities arising out of your use of these resources.

TI's products are provided subject to [TI's Terms of Sale](#) or other applicable terms available either on ti.com or provided in conjunction with such TI products. TI's provision of these resources does not expand or otherwise alter TI's applicable warranties or warranty disclaimers for TI products.

TI objects to and rejects any additional or different terms you may have proposed.

Mailing Address: Texas Instruments, Post Office Box 655303, Dallas, Texas 75265
Copyright © 2023, Texas Instruments Incorporated